



Refer to the *Installation Guide for Residential Floors* for additional information.
CCMC EVALUATION REPORT 13032-R

WEB HOLE SPECIFICATIONS

RULES FOR CUTTING HOLES AND DUCT CHASE OPENINGS:

- The distance between the inside edge of the support and the centerline of any hole or duct chase opening shall be in compliance with the requirements of Table 1 or 2, respectively.
- I-joint top and bottom flanges must NEVER be cut, notched, or otherwise modified.
- Whenever possible, field-cut holes should be centered on the middle of the web.
- The maximum size hole or the maximum depth of a duct chase opening that can be cut into an I-joint web shall equal the clear distance between the flanges of the I-joint minus 1/4 inch. A minimum of 1/8 inch should always be

maintained between the top or bottom of the hole or opening and the adjacent I-joint flange.

- The sides of square holes or longest sides of rectangular holes should not exceed 3/4 of the diameter of the maximum round hole permitted at that location.
- Where more than one hole is necessary, the distance between adjacent hole edges shall exceed twice the diameter of the largest round hole or twice the size of the largest square hole (or twice the length of the longest side of the longest rectangular hole or duct chase opening) and each hole and duct chase opening shall be sized and located in compliance with the requirements of Tables 1 and 2, respectively.
- A knockout is not considered a hole, may be utilized anywhere it occurs, and may be ignored for purposes of calculating minimum distances between holes and/or duct chase openings.

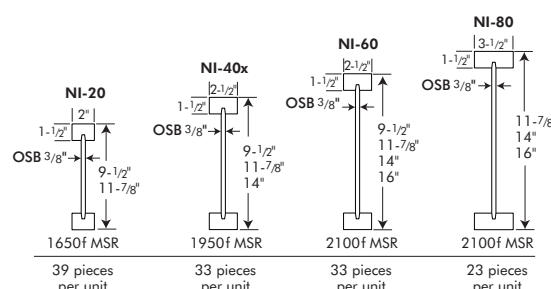

- One and one-half inch holes shall be permitted anywhere in a cantilevered section of a joist. Holes of greater size may be permitted subject to verification.
- A 1-1/2 inch hole can be placed anywhere in the web provided that it meets the requirements of item 6 above.
- For continuous joists with more than one span, use the longest span to determine hole location in either span.
- All holes and duct chase openings shall be cut in a workman-like manner in accordance with the restrictions listed above and as illustrated in Figure 7.
- Limit 3 maximum size holes and one duct chase opening per span.
- A group of round holes at approximately the same location shall be permitted if they meet the requirements for a single round hole circumscribed around them.

TABLE 1
HOLE SIZES AND LOCATIONS
Simple or Multiple Span

Joist Depth	Joist Series	Minimum Distance from Inside Face of Any Support to Center of Hole (ft - in.)														
		Round Hole Diameter (in.)														
		2	3	4	5	6	6-1/4	7	8	8-5/8	9	10	10-3/4	11	12	12-3/4
9-1/2"	NI-20	0'-6"	1'-0"	2'-0"	3'-6"	5'-0"	5'-0"									
	NI-40x	0'-6"	1'-6"	3'-0"	4'-6"	6'-0"	6'-6"									
	NI-60	0'-6"	1'-6"	3'-0"	4'-6"	6'-0"	6'-6"									
11-7/8"	NI-20	0'-6"	0'-6"	0'-6"	1'-0"	2'-6"	3'-0"	4'-0"	5'-6"	7'-0"						
	NI-40x	0'-6"	0'-6"	1'-6"	3'-0"	4'-0"	4'-6"	5'-6"	7'-0"	8'-6"						
	NI-60	0'-6"	1'-0"	2'-0"	3'-6"	5'-0"	5'-0"	6'-0"	8'-0"	9'-0"						
14"	NI-40x	0'-6"	0'-6"	0'-6"	1'-6"	2'-6"	3'-0"	4'-0"	5'-6"	6'-6"	7'-0"	8'-6"	10'-0"			
	NI-60	0'-6"	0'-6"	1'-0"	2'-6"	3'-6"	4'-0"	5'-0"	6'-6"	7'-6"	8'-0"	9'-6"	11'-0"			
	NI-80	0'-6"	1'-6"	2'-6"	4'-0"	5'-0"	5'-6"	6'-6"	8'-0"	9'-0"	9'-6"	11'-6"	13'-0"			
16"	NI-60	0'-6"	0'-6"	0'-6"	1'-6"	2'-6"	3'-0"	4'-6"	5'-0"	5'-6"	7'-6"	9'-0"	9'-6"	11'-6"	13'-0"	
	NI-80	0'-6"	0'-6"	1'-6"	3'-0"	4'-6"	4'-6"	5'-6"	7'-0"	8'-0"	8'-6"	10'-0"	11'-0"	11'-6"	13'-6"	15'-0"
	NI-80	0'-6"	0'-6"	1'-6"	3'-0"	4'-6"	4'-6"	5'-6"	7'-0"	8'-0"	8'-6"	10'-0"	11'-0"	11'-6"	13'-6"	15'-0"

- Above table may be used for I-joint spacing of 24 inches on center or less.
- Hole location distance is measured from inside face of supports to center of hole.
- For continuous joists with more than one span, use the longest span to determine hole location in either span.
- Distances are based on uniformly loaded floor joists that meet the span requirements for a design live load of 40 psf and dead load of 15 psf, and a live load deflection limit of L/480. For other applications, contact your local distributor.
- The above table is based on the I-joists being used at their maximum spans. The minimum distance as given above may be reduced for shorter spans; contact your local distributor.

TABLE 2
DUCT CHASE OPENING SIZES AND LOCATIONS
Simple Span Only

Joist Depth	Joist Series	Minimum Distance From Inside Face of Any Supports to Center of Opening (ft - in.)													
		Duct Chase Length (in.)													
		8	10	12	14	16	18	20	22	24					
9-1/2"	NI-20	5'-0"	5'-6"	5'-6"	6'-0"	6'-6"	7'-0"	7'-0"	8'-0"						
	NI-40x	4'-6"	5'-0"	5'-6"	6'-0"	6'-0"	6'-6"	7'-0"	7'-6"	8'-0"					
	NI-60	5'-0"	5'-0"	5'-6"	6'-0"	6'-0"	6'-6"	7'-0"	7'-6"	8'-0"					
11-7/8"	NI-20	6'-6"	7'-0"	7'-0"	7'-6"	8'-0"	8'-6"	9'-6"							
	NI-40x	6'-6"	6'-6"	7'-0"	7'-6"	8'-0"	8'-6"	9'-0"	9'-6"	10'-6"					
	NI-60	6'-6"	7'-0"	7'-6"	7'-6"	8'-0"	8'-6"	9'-0"	10'-0"	10'-6"					
14"	NI-40x	7'-6"	8'-0"	8'-6"	9'-0"	9'-6"	10'-0"	10'-6"	11'-6"	12'-0"					
	NI-60	8'-0"	8'-6"	9'-0"	9'-6"	10'-0"	10'-6"	11'-0"	12'-0"	12'-6"					
	NI-80	8'-0"	8'-6"	9'-0"	9'-6"	10'-0"	10'-6"	11'-0"	11'-6"	12'-0"					
16"	NI-60	9'-6"	10'-0"	10'-0"	11'-0"	11'-6"	12'-0"	12'-6"	13'-6"						
	NI-80	9'-6"	10'-0"	10'-6"	11'-0"	11'-6"	12'-0"	12'-6"	13'-6"	14'-0"					
	NI-80	9'-6"	10'-0"	10'-6"	11'-0"	11'-6"	12'-0"	12'-6"	13'-6"	14'-0"					

- Above table may be used for I-joint spacing of 24 inches on center or less.
- Duct chase opening location distance is measured from inside face of supports to center of opening.
- The above table is based on simple-span joists only. For other applications, contact your local distributor.
- Distances are based on uniformly loaded floor joists that meet the span requirements for a design live load of 40 psf and dead load of 15 psf, and a live load deflection limit of L/480.
- The above table is based on the I-joists being used at their maximum spans. The minimum distance as given above may be reduced for shorter spans; contact your local distributor.

FIGURE 7
FIELD-CUT HOLE LOCATOR

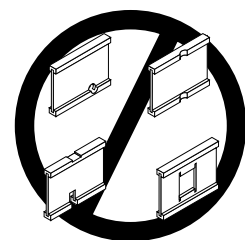
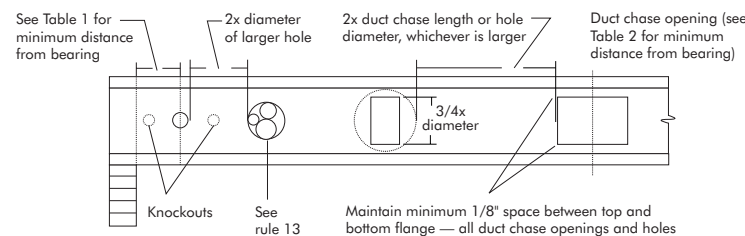

Knockouts are prescored holes provided for the contractor's convenience to install electrical or small plumbing lines. They are 1-1/2 inches in diameter, and are spaced 15 inches on center along the length of the I-joint. Where possible, it is preferable to use knockouts instead of field-cut holes.

Never drill, cut or notch the flange, or over-cut the web.

Holes in webs should be cut with a sharp saw.

For rectangular holes, avoid over-cutting the corners, as this can cause unnecessary stress concentrations. Slightly rounding the corners is recommended. Starting the rectangular hole by drilling a 1-inch diameter hole in each of the 4 corners and then making the cuts between the holes is another good method to minimize damage to I-joint.

SAFETY AND CONSTRUCTION PRECAUTIONS

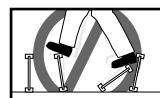

Do not walk on I-joists until fully fastened and braced, or serious injuries can result.

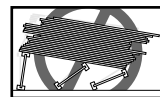

Never stack building materials over unsheathed I-joists. Once sheathed, do not over-stress I-joists with concentrated loads from building materials.

WARNING: I-joists are unstable until completely installed with panels fully fastened to the top flanges.

AVOID ACCIDENTS BY FOLLOWING THESE IMPORTANT GUIDELINES:

- Brace and nail each I-joint as it is installed, using hangers, blocking panels, rim board, and/or cross-bridging at joist ends.
- When the building is completed, the floor sheathing will provide lateral support for the top flanges of the I-joists. Until this sheathing is applied, temporary bracing, often called struts, or temporary sheathing must be applied to prevent I-joint rollover or buckling.
 - Temporary bracing or struts must be 1x4 inch minimum, at least 8 feet long and spaced no more than 8 feet on center, and must be secured with a minimum of two 2-1/2" nails fastened to the top surface of each I-joint. Nail the bracing to a lateral restraint at the end of each bay. Lap ends of adjoining bracing over at least two I-joists.
 - Or, sheathing (temporary or permanent) can be nailed to the top flange of the first 4 feet of I-joists at the end of the bay.
- For cantilevered I-joists, brace top and bottom flanges, and brace ends with closure panels, rim board, or cross-bridging.
- Install and nail permanent sheathing to each I-joint before placing loads on the floor system. Then, stack building materials over beams or walls only.
- Never install a damaged I-joint.

Improper storage or installation, failure to follow applicable building codes, failure to follow span ratings for Nordic I-joists, failure to use allowable hole sizes and locations, or failure to use web stiffeners when required can result in serious accidents. Follow these installation guidelines carefully.



PRODUCT WARRANTY

Chantiers Chibougamau guarantees that, in accordance with our specifications, Nordic products are free from manufacturing defects in material and workmanship.

Furthermore, Chantiers Chibougamau warrants that our products, when utilized in accordance with our handling and installation instructions, will meet or exceed our specifications for the lifetime of the structure.

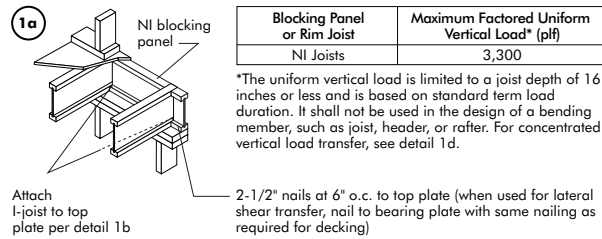

Blocking Panel or Rim Joist	Maximum Factored Uniform Vertical Load* (plf)
NI Joists	3,300

*The uniform vertical load is limited to a joist depth of 16 inches or less and is based on standard term load duration. It shall not be used in the design of a bending member, such as joist, header, or rafter. For concentrated vertical load transfer, see detail 1d.

Attach I-joint to top plate per detail 1b
2-1/2" nails at 6" o.c. to top plate (when used for lateral shear transfer, nail to bearing plate with same nailing as required for decking)

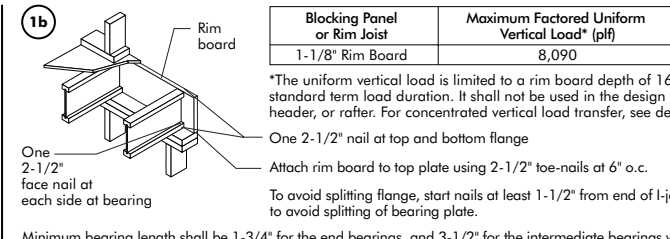

Blocking Panel or Rim Joist	Maximum Factored Uniform Vertical Load* (plf)
1-1/8" Rim Board	8,090

*The uniform vertical load is limited to a rim board depth of 16 inches or less and is based on standard term load duration. It shall not be used in the design of a bending member, such as joist, header, or rafter. For concentrated vertical load transfer, see detail 1d.

One 2-1/2" face nail at each side at bearing
Attach rim board to top plate using 2-1/2" toe-nails at 6" o.c.
To avoid splitting flange, start nails at least 1-1/2" from end of I-joint. Nails may be driven at an angle to avoid splitting of bearing plate.
Minimum bearing length shall be 1-3/4" for the end bearings, and 3-1/2" for the intermediate bearings when applicable.

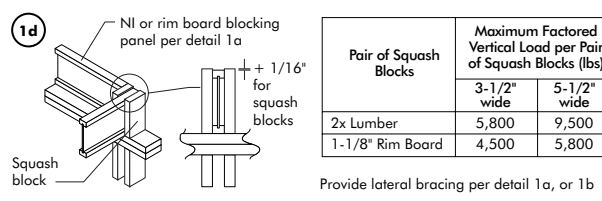

Pair of Squash Blocks	Maximum Factored Vertical Load per Pair of Squash Blocks (lbs)
3-1/2" wide	5,800
5-1/2" wide	9,500
1-1/8" Rim Board	4,500
	5,800

Provide lateral bracing per detail 1a, or 1b

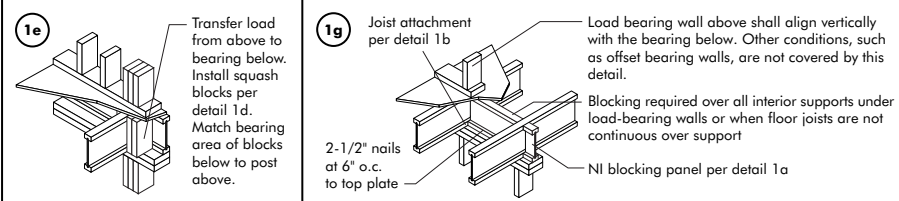

Transfer load from above to bearing below. Install squash blocks per detail 1d. Match bearing area of blocks below to post above.
Load bearing wall above shall align vertically with the bearing below. Other conditions, such as offset bearing walls, are not covered by this detail.
Blocking required over all interior supports under load-bearing walls or when floor joists are not continuous over support
2-1/2" nails at 6" o.c. to top plate
NI blocking panel per detail 1a
For nailing schedules for multiple beams, see the manufacturer's recommendations
Top- or face-mount hanger installed per manufacturer's recommendations
NOTE: Unless hanger sides laterally support the top flange, bearing stiffeners shall be used.
NOTE: Unless hanger sides laterally support the top flange, bearing stiffeners shall be used.

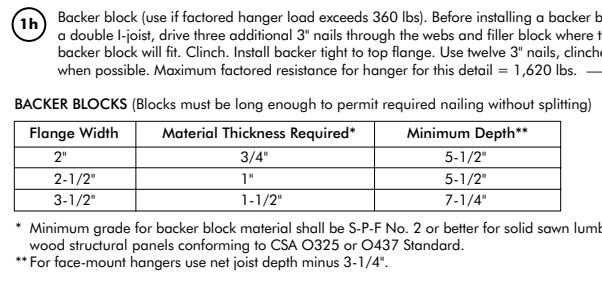
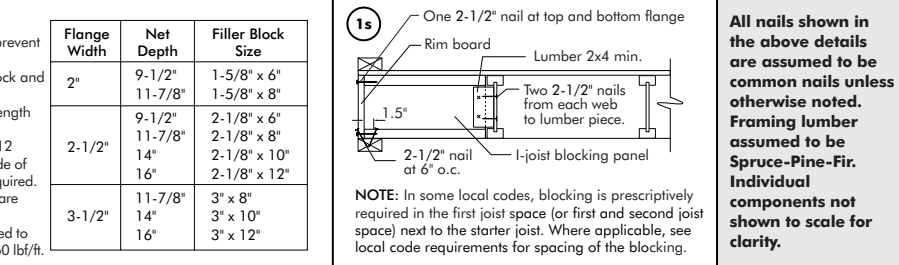
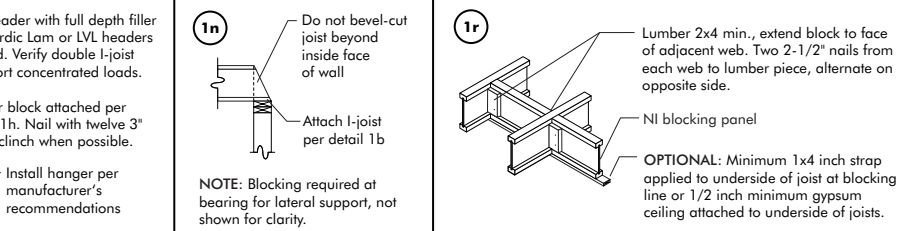
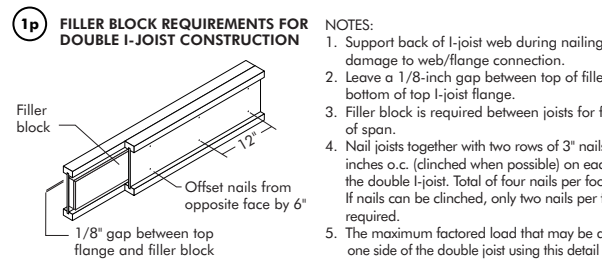
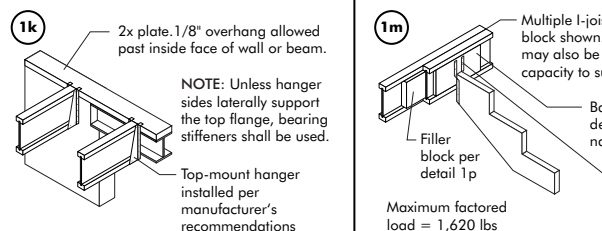
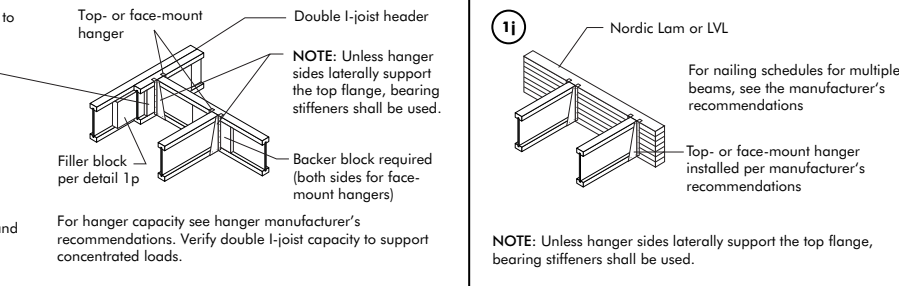

TABLE 3
BACKER BLOCKS (Blocks must be long enough to permit required nailing without splitting)

Flange Width	Material Thickness Required*	Minimum Depth**
2"	3/4"	5-1/2"
2-1/2"	1"	5-1/2"
3-1/2"	1-1/2"	7-1/4"

* Minimum grade for backer block material shall be S-P-F No. 2 or better for solid sawn lumber and wood structural panels conforming to CSA O325 or O437 Standard.
** For face-mount hangers use net joist depth minus 3/4".



WEB STIFFENERS

RECOMMENDATIONS:

- A **bearing stiffener** is required in all engineered applications with factored end reactions greater than 2,450 lbs. The gap between the stiffener and the flange is at the top.
- A **load stiffener** is required at locations where a factored concentrated load greater than the lesser of the factored shear resistance or 2,370 lbs is applied to the top flange between supports, or in the case of a cantilever, anywhere between the cantilever tip and the support. These values are for standard term load duration, and may be adjusted for other load durations as permitted by the code. The gap between the stiffener and the flange is at the bottom.
- A **bearing stiffener** is required when the I-joint is supported in a hanger and the sides of the hanger do not extend up to, and support, the top flange. The gap between the stiffener and flange is at the top.

FIGURE 2
WEB STIFFENER INSTALLATION DETAILS

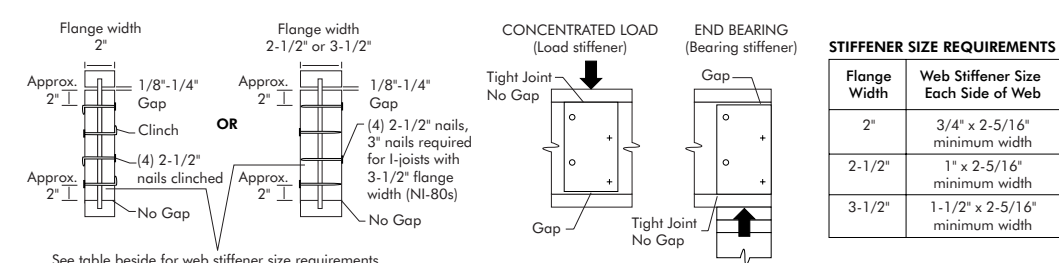

See table beside for web stiffener size requirements

CANTILEVER DETAILS FOR VERTICAL BUILDING OFFSET

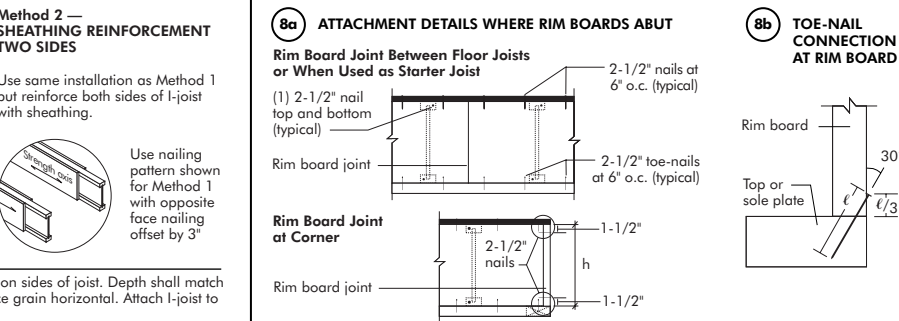
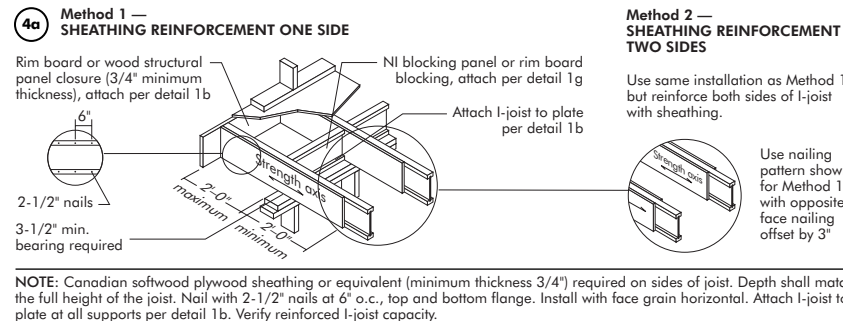

RIM BOARD INSTALLATION DETAILS

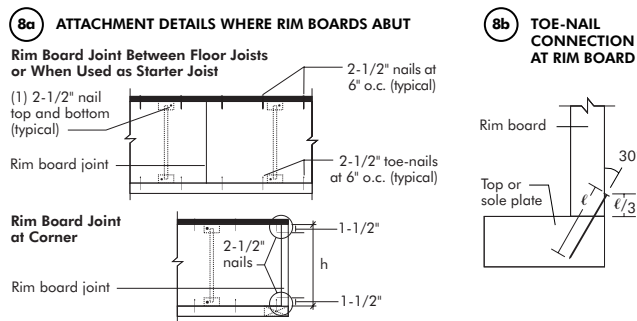

TOE-NAIL CONNECTION AT RIM BOARD

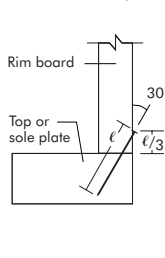

All nails shown in the above details are assumed to be common nails unless otherwise noted. Framing lumber assumed to be Spruce-Pine-Fir. Individual components not shown to scale for clarity.

Flange Width	Web Stiffener Size Each Side of Web
2"	3/4" x 2-5/16" minimum width
2-1/2"	1" x 2-5/16" minimum width
3-1/2"	1-1/2" x 2-5/16" minimum width